

HED
novarius

Dimmable electronic control gear: built-in version for high-intensity discharge lamps



Performance characteristics

- Dimmable electronic control gear for high-intensity discharge lamps in outdoor lighting, e.g. in street lighting
- Three dimming methods
 - DALI
 - geoDIM
 - control phase
- Service life 100 000 h at $t_c = t_{cmax}$
- Automatic recognition of HI and HS lamps
- Protection against transient overvoltage up to 10kV
- Potted electronics ensure protection against moisture
- Compact housing for application in slim outdoor luminaires
- Suitable for fixing with M4 screws
- Easy assembly using push-in terminals
- Flicker-free lamp operation
- Low noise emissions
- Safe lamp start from mains voltage 175 V
- Constant lamp output within $\pm 5\%$ in case of main power supply fluctuation of $\pm 10\%$
- Maximum lamp service life through optimum operation
- Automatic switch off in case of overheating
- Automatic switch off when end-of-life effect is detected
- Automatic safety switch off in case of abnormal lamp operation, e.g. at end of life
- Switch off in case of mains overvoltage from 320 V
- Switch off in case of mains undervoltage from 170 V
- Switch off ignition within 19 minutes; reset only through interruption of mains voltage
- Status display with three coloured LED's: correct operation, network error, abnormal lamp operation
- Reliable lamp start up to -25°C
- Maximum distance ECG / lamp: 10 m
- suitable for luminaires with protection class I and II

ECG model

Version	Order no.	Lamp
HED70.1QS-01 220-240/DALI outdoor	10077595	HS
		Philips CDO 70...
		GE CMH 70... Street Wise
		Osram HCI-TT 70...
		Aura Crystal EP, TT, Longlife 70
HED100.1QS-01/ 220-240/DALI outdoor	10077594	HS
		HI (Quarz)*
		HI-CE Philips CDO 100..., CDM 100...*
		HI-CE GE CMH 100... Street Wise, CHM 100...*
		HI-CE OSRAM HCI-TT 100..., HCI 100...*
		Aura Crystal EP, TT, Longlife 100

* no dim function

Compliances and markings

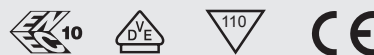



Dimmable electronic control gear: built-in version for high-intensity discharge lamps

Technical data

Mains voltage supply	
Nominal voltage range	220 V – 240 V
Max. admissible voltage range (continuous)	198 V – 264 V
Frequency	50 Hz ... 60 Hz
Overvoltage protection, mains side	
	320V/48 h 350V/2 h
Voltage strength to slow surge, symmetrical	6 kV
Voltage strengths to slow surge asymmetrical	8 kV, 10kV for single shot
Leakage current	< 0,5 mA / EVG
Load capacity	700 pF (HED70.1QS) 1000 pF (HED100.1QS)
Nominal service life	100.000 h with a failure rate of ≤ 10% and operation at $t_c = t_{c, max}$
Connections	
Push-in terminals	0,5 mm ² – 2,5 mm ²
Wire stripping length	10 mm
Max. eff. operation voltage U_{OUT}	250 V
Clearance and creepage distance from any metal part in luminaires to be earthed environment (class I) or test finger (class II)	> 5 mm

Admissible temperatures

Version	Ambient (t_a)	Case (t_c)
HED70.1QS	- 25 °C ... + 55 °C	max. + 75 °C
HED100.1QS	- 25 °C ... + 55 °C	max. + 80 °C

Inrush current/Circuit breaker

Version	typ $I_{peak} / \Delta t$	No. of ECG at single-pole circuit breakers				
		LS-Typ	10 A	16 A	20 A	25A
HED70.1QS	2,4 A / 3,7 ms	B	11	17	22	27
		C	18	29	36	45
HED100.1QS	2,8 A / 8,5 ms	B	9	14	17	21
		C	14	23	29	36

All data for $U_{supply} = 230$ VAC, mains impedance = 400 mΩ.
The max. number may differ depending on CB manufacturer. Please consider the specifications of the manufacturer.
Basically, CB with C-characteristics are recommended to be used in lighting groups.

Fig. 1

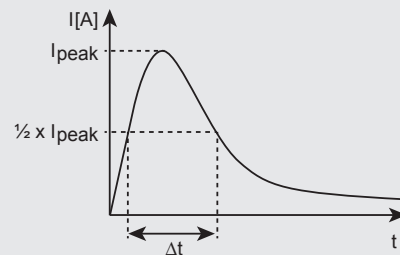

Standards compliance

EN 61 347-1	General and safety requirements
EN 61 347-2-9	
EN 61000-3-2	Limits for harmonic current emissions
EN 61000-3-3	Limitation of voltage fluctuations and flicker
EN 61547	EMC immunity
EN 55015	Radio disturbances



Dimmable electronic control gear: built-in version for high-intensity discharge lamps

The geoDIM technology

GeoDIM

New: The geoDIM function for outdoor lamps responds automatically and intelligently to the real-life day and night cycles, depending on the degree of latitude. The geoDIM function works reliably along all parallels from the equator to the 65. parallel near the arctic circle.

The system calculates the real night length based on local switch on/off handling for three nights. This night time cycle is interpreted to set an energy saving dim phase

- 100% light output for the first 30% of the night cycle
- 50% light output for next 50% of the night cycle
- 100% light output for the last 20% of the night cycle

Advantages:

- Energy efficiency and cost reduction through intelligent dimming behaviour
- No additional wiring (only mains power supply)
- Adaptive response to different seasonal night cycles
- No programming necessary
- Reliable operation from Caracas to Oslo
- Real time measurement for several nights avoids errors through short term switch on/off

Examples of night cycles and corresponding power reduction, depending on the geographical degree of parallel

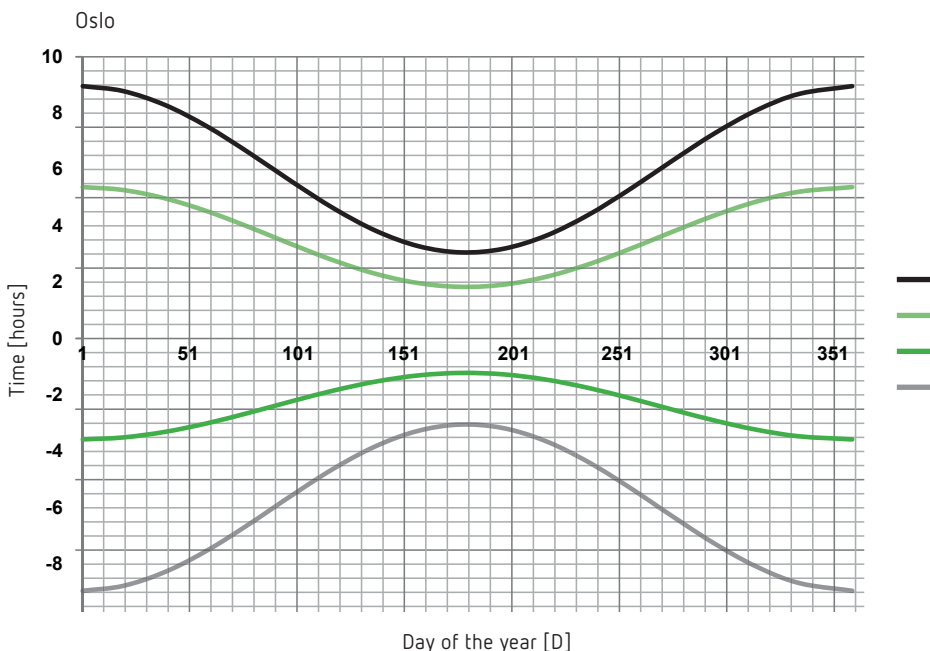
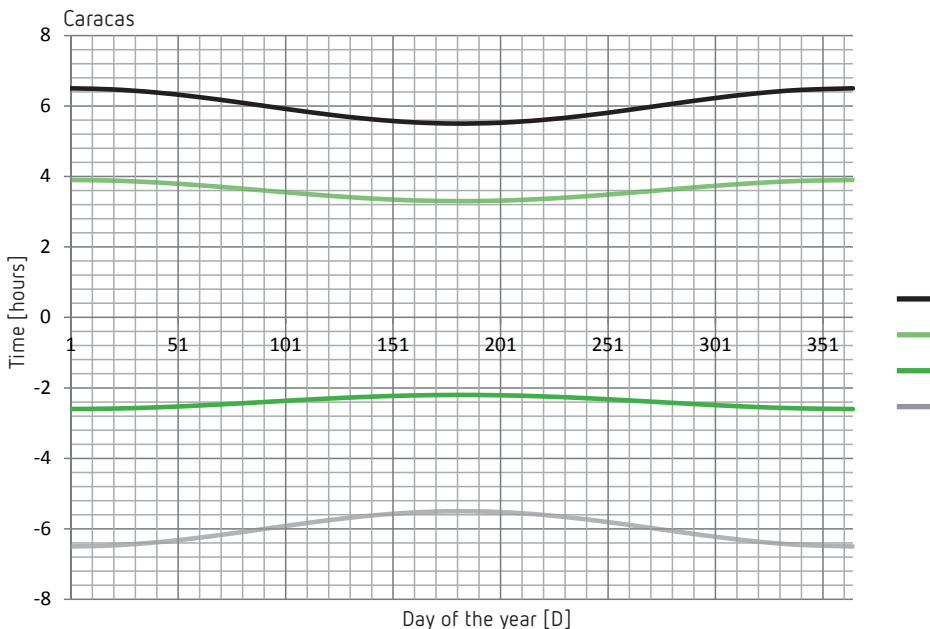

HED
novarius

Dimmable electronic control gear: built-in version for high-intensity discharge lamps

Operating data

Version	Lamp power	System-rating	Input current	Operating frequency	Power factor	Ignition voltage
	W	W	A	Hz		kV
HED70.1QS	73	80	0,35	166	> 0,97	1,9 ... 2,5
HED100.1QS	100	110	0,48	166	> 0,97	3 ... 5

Dimensions

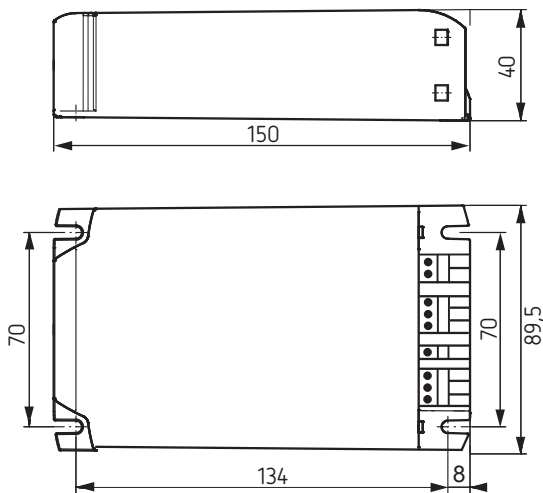

Version	Packing	Weight
	pcs./box	kg
HED70.1QS	10	0,76
HED100.1QS	10	0,78

Wiring diagrams

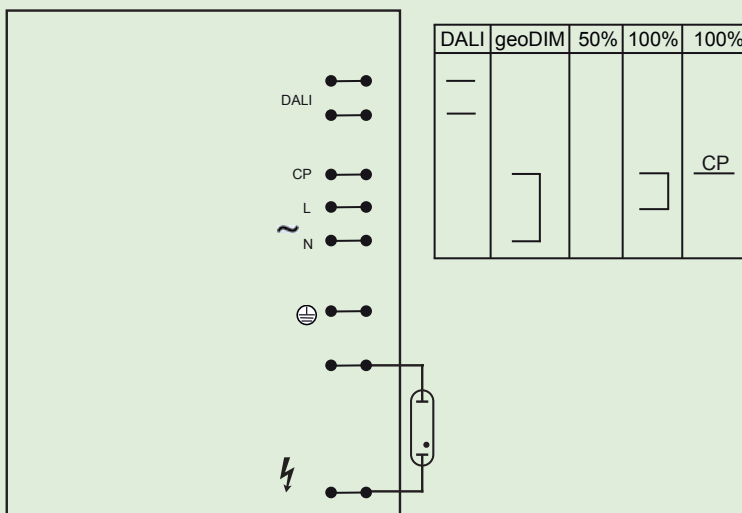

CP= Control Phase

Where a DALI command is detected, DALI dominates over all other dimming methods.

geoDIM